



## Clutch Installation Guidelines – Follow Service Manual Instructions For Step-By-Step Procedures

### FAILURE TO FOLLOW PROPER INSTALLATION OR BREAK-IN PROCEDURES WILL VOID ANY WARRANTY

1. Always disconnect negative battery cable prior to doing any major work on your vehicle.
2. When removing your old clutch, note which way the clutch disc was facing (spring pack facing engine or transmission). You will want to install the new disc with the same orientation as the old disc you removed.
3. Before installing your new clutch clean the inner bellhousing area to make sure no debris gets onto the new clutch. Also inspect clutch bar for any damage (cracks, excessive wear etc...).
4. Remove flywheel and either resurface or replace. **The flywheel must have a fresh surface for the clutch disc to mate to!** Failure to resurface the flywheel can result in shorter clutch life and abnormal wear or vibration. If the flywheel is discolored from excessive heat, you may need to replace it.
5. Install flywheel using a small amount of Loctite on the flywheel bolts. Torque the bolts in a star pattern. See the chart below for proper torque specs. **2RZ/3RZ flywheel bolts can not be re-used! These are a torque-to-yield bolt that are only intended to be torqued down once. New flywheel bolts are available from LC Engineering.**
6. Install new pilot bearing in crankshaft. Failure to replace pilot bearing can result in annoying squeal noises when cold. We supply a new pilot bearing in all of our clutch kits.
7. Place clutch disc on flywheel, using the supplied alignment tool to make installation of the transmission easier. For all 20R, 22R, 22RE, 22RET, 2RZ, and 3RZ clutches, the spring side of the clutch disk faces the pressure plate/transmission. For 5VZ V6 clutches, the spring side faces the flywheel. If there is any confusion refer back to which way the stock disc was facing.
8. Install pressure plate onto flywheel, making sure to align the dowel pins in the flywheel with the corresponding holes in the pressure plate. Verify that the alignment tool keeps the clutch disk centered in the assembly (do not let the tool just hang on its own, you need to keep it centered as you install the pressure plate. Torque bolts evenly a little at a time in a star pattern. **If the pressure plate is not torqued evenly in steps it can cause the plate to warp, this will not be covered under warranty.** LC Engineering recommends tightening the pressure plate with hand tools only. Refer to chart below for torque specs. Remove alignment tool.
9. Replace throw-out bearing. The throw-out bearing is held in with two retaining clips that hold it to the clutch fork. **NOTE: If you receive a clutch kit with (2) throw out bearings due to year / fitment overlap, you will need to use the bearing that matches the original one that was installed in your vehicle, failure to do so will cause the clutch to work improperly.**
10. Lubricate all moving parts; input shaft, pressure plate “finger” tips, throw out bearing contact surfaces etc... with white lithium grease or Anti-sieze. This will ensure smooth performance and engagement of the clutch.
11. With the new throw out bearing in place, slide the transmission onto the engine, being extremely careful not to let the weight of the transmission hang on the clutch disk. This can cause serious damage to the disk. With the clutch disk properly aligned during installation, the input shaft should not require any force to install. Rocking the transmission or turning the output shaft as you install the tranny may help if it doesn't go in all the way. **DO NOT USE THE BELLHOUSING BOLTS TO DRAW THE TRANSMISSION AND ENGINE TOGETHER!** This can result in serious damage, especially to the new clutch or the thrust bearings inside the engine, and should not be necessary if everything is installed and aligned properly.
12. Re-install slave cylinder and other components you may have removed to gain access to the clutch.
13. If needed, bleed clutch hydraulic system according to repair manual.
14. Road test vehicle, avoiding aggressive driving for the first 500-750 miles. Proper break-in procedure is crucial to long service life out of your new clutch.

Engine	Flywheel Torque	Pressure Plate Torque
20R/22R/RE/RET	80 Ft-Lbs	11-15 Ft-Lbs
3VZ	65 Ft-Lbs	11-15 Ft-Lbs
5VZ	61 Ft-Lbs	14 Ft-Lbs
2RZ/3RZ	19 Ft-Lbs + 90 Degrees	14 Ft-Lbs



## General Misalignment Issues / Tips

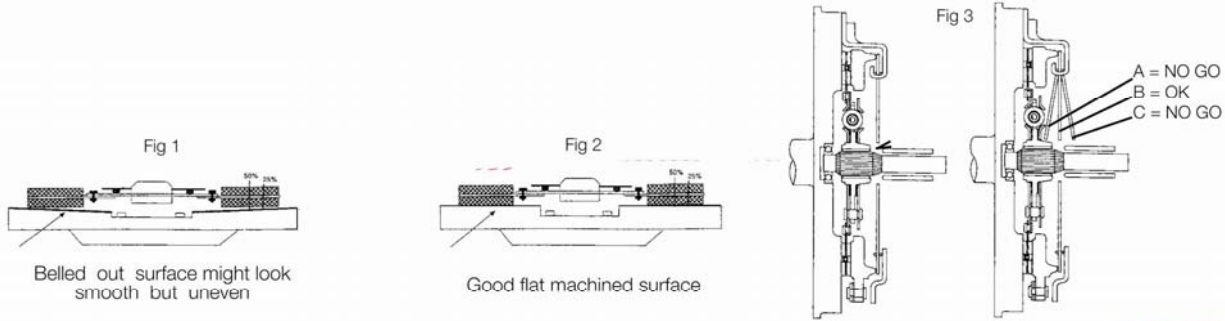

1. Check for a warped alloy bell housing
2. Examine tubular dowel pins for damage during fitting of bell housing or for missing dowel pins.
3. Examine gearbox quill/gearbox main drive nose cone/bearing slide: Excessive wear can cause bearing to come in contact with the cover assembly diaphragm unevenly while actuating the clutch.
4. Ensure the proper mating of bell housing to motor, and crankshaft to flywheel. These may not mate properly due to debris, grease or other parts in the way of the mating surfaces.
5. Examine all bearings/bushings for excessive wear, replace if necessary.
6. Replacement engines and gearboxes may have missing dowel pins. Ensure that you remove pins from your product when you send your core for remanufacture, and refit or replace them when installing new clutch.

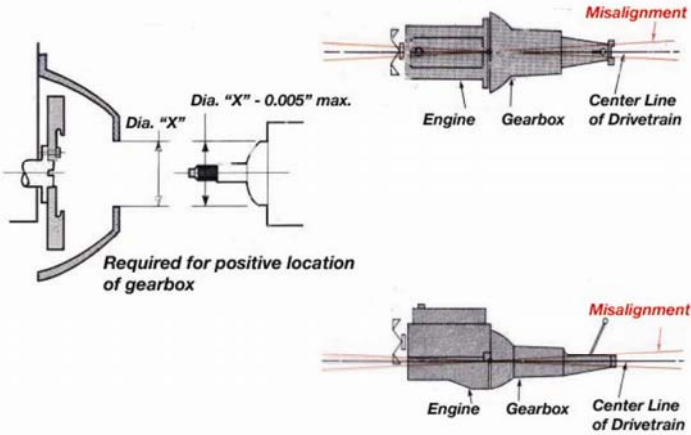

## Hanging the Gearbox

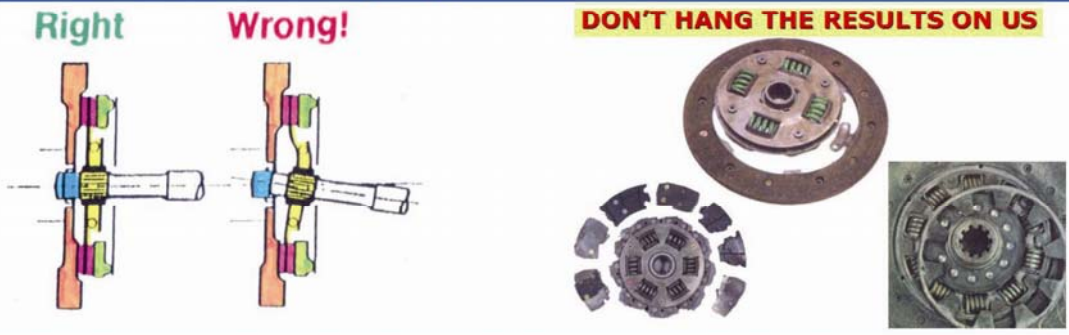

## Examples of Common Warranty Exclusions

